

HYPNEUMAT INC.

AUTOMATIC DRILLING & TAPPING UNITS

LS-300 & LS-500 PIPING FOR BASIC LEAD SCREW TAPPING-DRILLING CIRCUIT WITH AIR RAPID APPROACH AND AIR BRAKE MOTOR

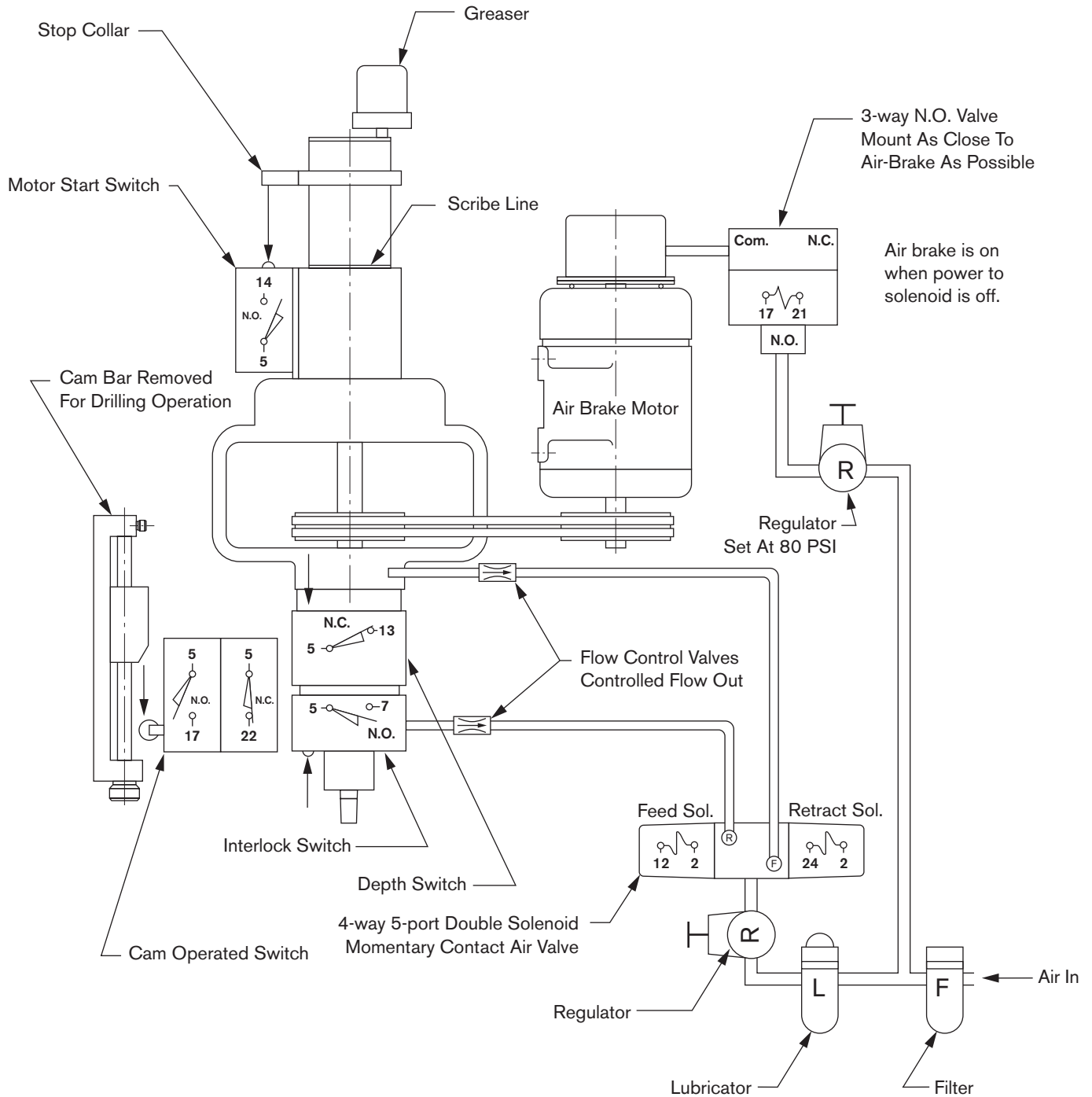

**LS-300 & LS-500
BASIC LEAD SCREW TAPPING-DRILLING CIRCUIT
WITH AIR RAPID APPROACH AND AIR BRAKE MOTOR**

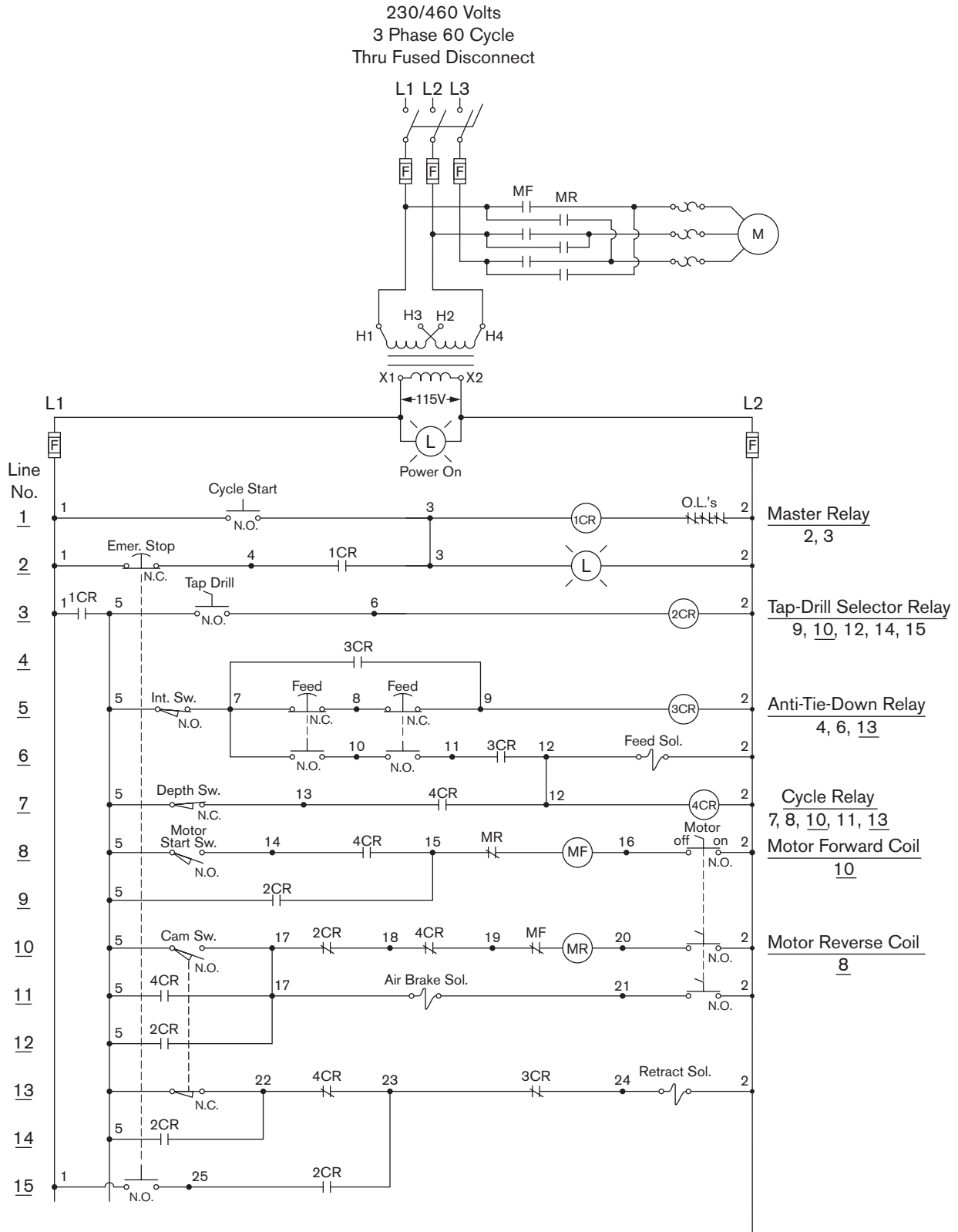

IMPORTANT

THIS CIRCUIT IS A BASIC METHOD OF CONTROLLING HYPNEUMAT EQUIPMENT.
CHECK LOCAL, STATE, & OSHA REGULATIONS FOR SPECIFIC CIRCUIT REQUIREMENTS.

LS-300 & LS-500
**CYCLE SEQUENCE FOR LEAD SCREW TAPPING-DRILLING
 CIRCUIT WITH AIR RAPID APPROACH AND AIR BRAKE MOTOR**
LEAD SCREW TAP OPERATION SEQUENCE

1. Turn Tap-Drill selector switch to "TAP"
2. Turn Motor Selector Switch to "ON"
3. Push Cycle start Button
 - a. Supplies power to circuit (1CR)
4. Push Twin Palm Feed Buttons
 - a. Valve shifts for Rapid Approach
 - b. 4CR is energized
 - c. Brake is released and unit moves forward
5. Stop Collar on Lead Screw Cartridge makes contact with Motor Start Switch
 - a. Motor starts clockwise rotation (MF)
6. Cam Operated Switch is set to actuate just after Motor Start Switch is actuated
7. Depth Switch is actuated at depth required
 - a. 4CR is dropped out
 - b. Motor starts counterclockwise rotation (MR)
 - c. Valve "does not" shift
8. Cam Switch drops off Cam
 - a. Power to Motor is shut off
 - b. Brake is energized
 - c. Valve shifts to Rapid Retract position

EMERGENCY STOP (Tap in part)

1. Push Emergency Stop Button, causes all motion to stop
2. To return unit to back position, Cycle Start Button must be pressed and unit will automatically go to normal position

NO HOLE IN PART

1. Unit rapid approaches
2. Normal Cycle begins
3. Tap makes contact with part
4. Unit cannot feed forward so Lead Screw Cartridge backs out of Rear Housing backing off of cartridge causes Motor Start Switch to deactivate

RETURNING UNIT TO START POSITION

1. Push Emergency Stop
2. Push Cycle Start Button (unit retracts)
3. Remove part and cycle unit one time to allow unit to reset scribe line in cartridge

NOTE: a. In this circuit "Cam Switch" has no function on the way in

NOTE: b. The "Motor Start Switch" has no function on the way out

DRILL OPERATION SEQUENCE

1. Turn Tap-Drill Selector Switch to "DRILL"
2. Turn Motor Selector Switch to "ON"
3. Push Cycle Start Button
 - a. Supplies power to Circuit (1CR)
4. Push Twin Palm Feed Buttons
 - a. Valve shifts for and unit feeds forward
5. Depth Switch is actuated at depth required
 - a. Valve shifts and unit rapid retracts

EMERGENCY STOP

1. Push Emergency Stop Button
 - a. 1CR Master Relay drops out
 - b. Motor shuts off and coasts to stop
 - c. Valve shifts and unit rapid retracts

OPTIONAL PIPING FOR DUAL PRESSURE SYSTEM

Note!

This System Used For Vertical Operation With Heavy Multiple Spindle Heads. Separate Pressures For Feed And Retract Strokes.

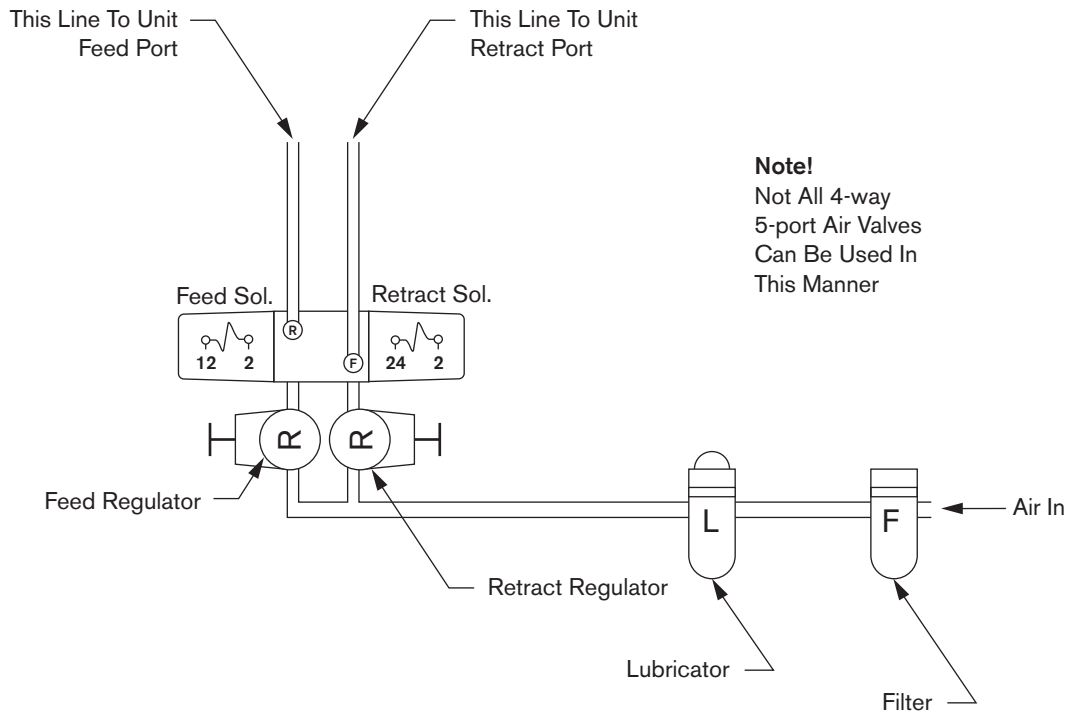

Visit us on the World Wide Web at <http://www.hypneumat.com>

Hypneumat Inc.
5900 West Franklin Drive
Franklin, WI 53132-9178
Phone: (414) 423-7400
Fax: (414) 423-7414

HYPNEUMAT INC.
AUTOMATIC DRILLING & TAPPING UNITS