

Commander®**MULTIPLE SPINDLE DRILL HEAD****MULTI-DRILL®****950****Sturdy, Compact Head with Heavy-Duty Capabilities**

- *Drill / Tap up to 10 holes in a 8-1/4" diameter circle or 22" circle with extension spindles*
- *1/2" drill capacity*
- *Adapts to any drill press or automatic feed unit.*
- *1:2 ratio is suited for tapping fine pitches*

The Model 950 Multi-Drill is a ruggedly constructed, heavy-duty multiple spindle drill head. It features precision built anti-friction gear case drive with ball and roller bearings and extra-strength gear train. It is capable of withstanding high torque and thrust in keeping with rated capacity.

MULTI-DRILL 950	ITEM #
Basic Unit without Adaptation	C90407
Basic Unit with Adaptation	C90408

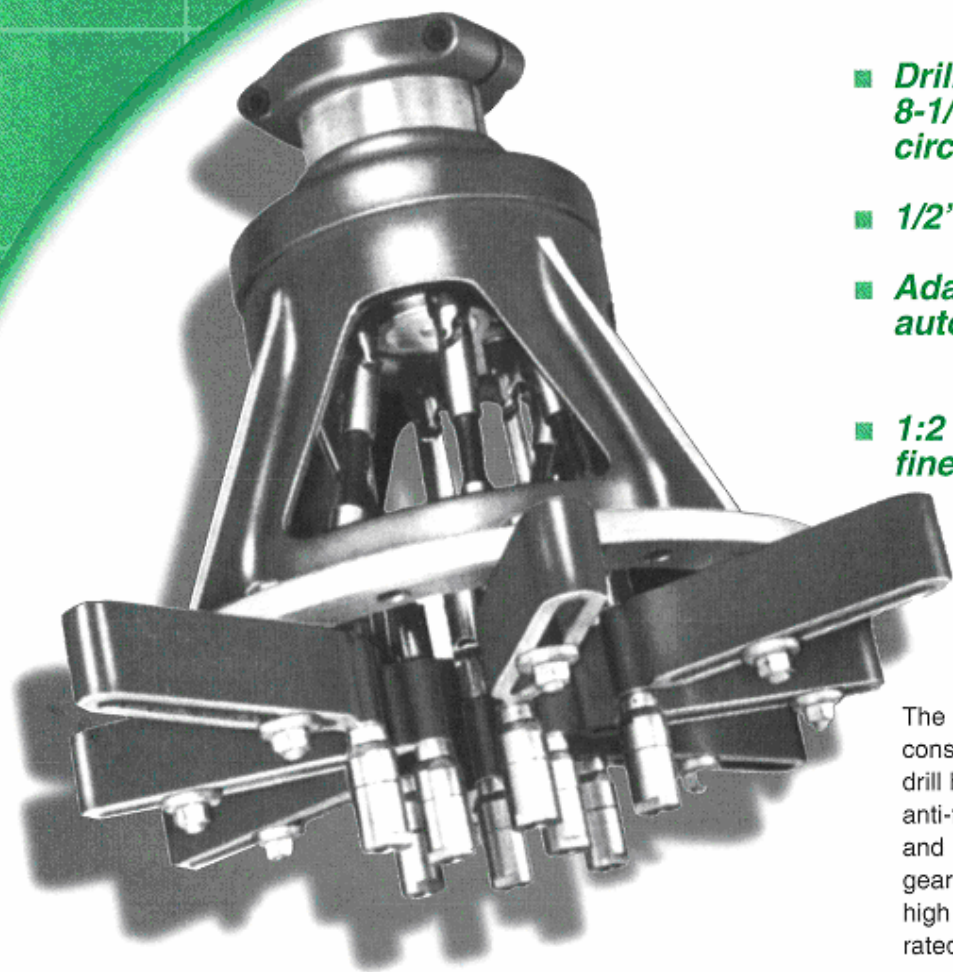

Proudly made in Franklin, WI USA

SPECIFICATIONS	
Maximum Drilling Area	8-1/4" diam.
Minimum Center Distance	7/16" diam.
Maximum Number of Spindles	10
Drill Capacity in mild steel	1/2"
Maximum Drilling Area w/ Extension Spindles	22"
Maximum Horsepower Transmitted	2
Maximum Torque Transmitted	70 inch / lbs.
Maximum Spindle RPM	1800
Maximum Drill Press RPM	950
Speed Ratio	1:2

www.commandermultidrill.com

Ideal for adaptation to drill presses, tapping machines, automatic self-feed drill and tap units, and special machines

- Spindle capacity 1/2" in mild steel.
- Heavy-duty gear case allows drilling up to 10 holes
- Close center capacity.
- Operate in any position: upright, inverted or horizontal.
- Adapt to any drilling machine. Standard adapter caps available to fit most popular drilling machines.
- These drill heads can be used for multiple tapping by use of a motor reversing unit.
- Minimum maintenance required.
- Extremely versatile, maximum flexibility of application.
- Ten 3/8" hex drives are included.*

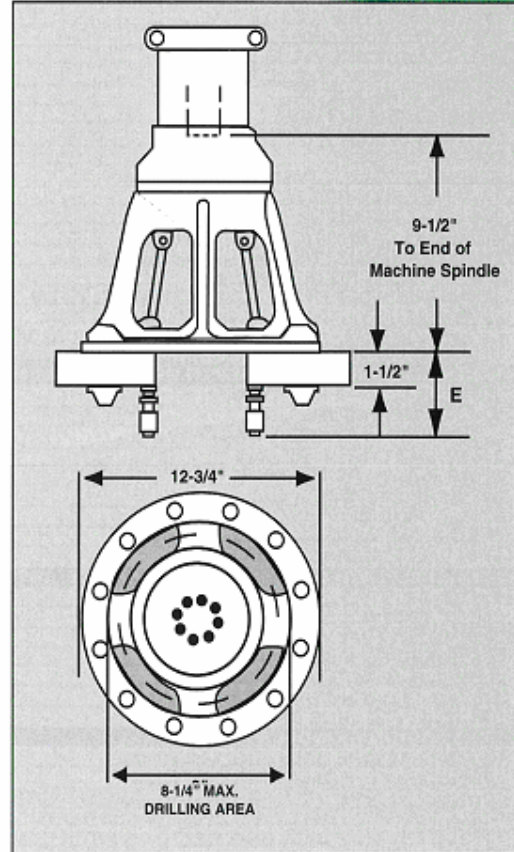

Commander Multi-Drill has on file spindle specifications for most machines. Please furnish us with the make and model number of the machine that our head will be adapted to. (See adaptations page)

In some cases there may be an additional charge for adaptation.

*** Multi-Drill Terminology...
Hex Pick-Off**

A Hex Pick-Off is the hex protruding from the multi-drill gear case that a universal joint spindle can be attached to.

The model 950 includes all 10 hex pick-offs with the basic unit.

The maximum angularity of universal joint assemblies should be no more than 22 degrees to obtain best service life.

MULTI-DRILL® 950 ADJUSTABLE ARM



Minimum Center Distances	Spindle Length "E" Dimension <i>see drawing</i>		Adjustable Arm	
	Plain	Booted	Plain	Booted

STANDARD SPINDLE ASSEMBLIES					
125 COLLET TYPE 1/32 TO 1/8	1/2	-----	3-5/16	C74490	-----
125 COLLET TYPE 1/32 TO 1/8	7/16	-----	3-5/16	C74579	-----
125 BORED TYPE .255" MAX.	1/2	-----	3-1/8	C74495	-----
265 COLLET TYPE 1/32 TO 17/64	11/16	-----	3-9/16	C74496	-----
265 COLLET TYPE 1/32 TO 17/64	5/8	-----	3-9/16	C74581	-----
265 BORED TYPE .4375" MAX.	5/8	-----	3-1/8	C74582	-----
375 COLLET TYPE 1/32 TO 3/8	5/8	1-1/4	3-5/8	C74498	C75498
375 BORED TYPE .500" MAX.	5/8	1-1/4	3-3/8	C74500	C75500
#1 MORSE TAPER TYPE	5/8	1-1/4	5	C74501	C75501
375 Q.T. FLOATING TAP SPINDLES	7/8	1-1/4	P.O.A.	P.O.A.	P.O.A.
375 Q.C. FLOATING TAP SPINDLES (BILZ)	7/8	1-1/4	P.O.A.	P.O.A.	P.O.A.
375 PLAIN FLOATING SPINDLES	7/8	1-1/4	P.O.A.	P.O.A.	P.O.A.
BALL BEARING SPINDLE ASSEMBLIES					
375 COLLET TYPE 1/32 TO 3/8	-----	1-1/4	3-3/16	-----	C85318
375 BORED TYPE .500" MAX.	-----	1-1/4	3-3/16	-----	C85474
500 COLLET TYPE 1/32 TO 1/2	-----	1-1/4	3-5/8	-----	C85323
500 BORED TYPE .625" MAX.	-----	1-1/4	3-5/8	-----	C85470
#1 MORSE TAPER TYPE	-----	1-1/4	4-9/16	-----	C85319
#2 MORSE TAPER TYPE	-----	1-1/4	4-15/16	-----	C85320
5/8 ASA SPINDLE	-----	1-1/4	5-5/16	-----	C85321
7/8 ASA SPINDLE	-----	1-1/4	5-15/16	-----	C85322
STUB ASA COLLET TYPE (SPECIFY BORE)	-----	1-1/4	4-5/16	-----	C85403
375 PLAIN FLOATING TAP SPINDLES	-----	1-1/4	3-3/16	-----	C85469
375 Q.T. FLOATING TAP SPINDLES	-----	1-1/4	3-3/16	-----	C85384
375 Q.C. FLOATING TAP SPINDLES (BILZ)	-----	1-1/4	3-3/16	-----	C85387
500 Q.C. FLOATING TAP SPINDLES (BILZ)	-----	1-1/4	3-5/8	-----	C85388
500 Q.T. FLOATING TAP SPINDLES	-----	1-1/4	3-5/8	-----	C85385
ADJUSTABLE DEPTH 375 COLLET TYPE 1/32 TO 3/8	-----	1-1/4	4-3/8	-----	C85419
ADJUSTABLE DEPTH 375 BORED TYPE .500" MAX.	-----	1-1/4	4-3/8	-----	C85483
PITCH COMPENSATING 375 COLLET TYPE 1/32 TO 3/8	-----	1-1/4	4-1/8	-----	C85429
PITCH COMPENSATING 375 BORED TYPE .500" MAX.	-----	1-1/4	4-1/8	-----	C85484
STANDARD ADJUSTABLE DEPTH SPINDLE ASSEMBLIES					
125 COLLET TYPE 1/32 TO 1/8	1/2	-----	3-5/8	C74522	-----
125 BORED TYPE .255" MAX.	1/2	-----	3-5/8	C74586	-----
265 COLLET TYPE 1/32 TO 17/64	11/16	-----	3-7/8	C74523	-----
265 BORED TYPE .4375" MAX.	11/16	-----	3-7/8	P.O.A.	-----
375 COLLET TYPE 1/32 TO 3/8	7/8	1-1/4	3-7/8	C74524	C75524
375 BORED TYPE .500" MAX.	7/8	1-1/4	3-7/8	C74527	C75527
375 Q.T. FLOATING TAP SPINDLES	-----	-----	-----	-----	P.O.A.
375 Q.C. FLOATING TAP SPINDLES (BILZ)	-----	-----	-----	-----	P.O.A.
375 PLAIN FLOATING SPINDLE	-----	-----	-----	-----	P.O.A.
STANDARD PITCH COMPENSATING SPINDLE ASSEMBLIES					
125 BORED TYPE .255" MAX.	1/2	-----	3-5/8	C74532	-----
265 BORED TYPE .255" MAX.	11/16	-----	3-7/8	P.O.A.	-----
375 COLLET TYPE #0-5/16 TAP	7/8	1-1/4	3-7/8	C74535	C75535
375 BORED TYPE 5/16" TAP MAX.	7/8	1-1/4	3-7/8	P.O.A.	P.O.A.
375 Q.T. FLOATING TAP SPINDLES	-----	-----	-----	P.O.A.	P.O.A.
375 Q.C. FLOATING TAP SPINDLES (BILZ)	-----	-----	-----	P.O.A.	P.O.A.
375 PLAIN FLOATING SPINDLES	-----	-----	-----	P.O.A.	P.O.A.
3" EXTENSION SPINDLES					
375 COLLET TYPE BALL BRG. 1/32 TO 3/8	1-3/8	1-3/8	3-5/8	C74514	C75514
375 BORED TYPE BALL BRG. .500" MAX.	1-3/8	1-3/8	3-3/8	C74516	C75516
375 COLLET TYPE BALL BRG. 1/32 TO 3/8 ADJ DEPTH	1-3/8	1-3/8	3-3/8	C74518	C75518
375 BORED TYPE BALL BRG. .500 MAX ADJ DEPTH	1-3/8	1-3/8	3-3/8	C74520	C75520
375 COLLET TYPE BALL BRG. 1/32 TO 3/8 PITCH COMP	1-3/8	1-3/8	3-3/8	C74521	C75521
375 BORED TYPE BALL BRG. .500 MAX PITCH COMP	1-3/8	1-3/8	3-3/8	P.O.A.	P.O.A.
500 COLLET TYPE BALL BRG. 1/32 TO 1/2	1-3/8	1-3/8	4-9/16	C74547	C75547
500 BORED TYPE BALL BRG. .625 MAX	1-3/8	1-3/8	3-13/16	C74548	C75548
#1 MORSE TAPER TYPE	1-3/8	1-3/8	4-11/16	C74545	C75545
#2 MORSE TAPER TYPE	1-3/8	1-3/8	5-7/16	C74546	C75546
375 Q.T. FLOATING TAP SPINDLES	-----	-----	-----	P.O.A.	P.O.A.
375 Q.C. FLOATING TAP SPINDLES (BILZ)	-----	-----	-----	P.O.A.	P.O.A.
375 PLAIN FLOATING SPINDLES	-----	-----	-----	P.O.A.	P.O.A.
6 3/4" EXTENSION SPINDLES					
375 COLLET TYPE BALL BRG. 1/32 TO 3/8	1-3/8	1-3/8	3-5/8	C74506	C75506
375 BORED TYPE BALL BRG. .500" MAX.	1-3/8	1-3/8	3-3/8	C74508	C75508
375 COLLET TYPE BALL BRG. 1/32 TO 3/8 ADJ DEPTH	1-3/8	1-3/8	3-3/8	C74510	C75510
375 BORED TYPE BALL BRG. .500 MAX ADJ DEPTH	1-3/8	1-3/8	3-3/8	C74512	C75512
375 COLLET TYPE BALL BRG. 1/32 TO 3/8 PITCH COMP	1-3/8	1-3/8	3-3/8	C74513	C75513
375 BORED TYPE BALL BRG. .500 MAX PITCH COMP	1-3/8	1-3/8	3-3/8	P.O.A.	P.O.A.
500 COLLET TYPE BALL BRG. 1/32 TO 1/2	1-3/8	1-3/8	4-9/16	C74543	C75543
500 BORED TYPE BALL BRG. .625 MAX	1-3/8	1-3/8	3-13/16	C74544	C75544
#1 MORSE TAPER TYPE	1-3/8	1-3/8	4-11/16	C74541	C75541
#2 MORSE TAPER TYPE	1-3/8	1-3/8	5-7/16	C74542	C75542
375 Q.T. FLOATING TAP SPINDLES	-----	-----	-----	-----	-----
375 Q.C. FLOATING TAP SPINDLES (BILZ)	-----	-----	-----	-----	-----
375 PLAIN FLOATING SPINDLES	-----	-----	-----	-----	-----
VERSA SPINDLES					
3/8" CAPACITY	-----	-----	-----	-----	C80142
1/2" CAPACITY	-----	-----	-----	-----	C80149



Plain



Booted

MULTI-DRILL® 950 SLIP SPINDLE



Minimum Center Distances	Spindle Length "E" Dimension <i>see drawing</i>		Slip Spindle	
	Plain	Booted	Plain	Booted

STANDARD SPINDLE ASSEMBLIES					
125 COLLET TYPE 1/32 TO 1/8	1/2	-----	3-5/16	C74549	-----
125 COLLET TYPE 1/32 TO 1/8	7/16	-----	3-5/16	P.O.A.	-----
125 BORED TYPE .255" MAX.	1/2	-----	3-1/8	C74554	-----
265 COLLET TYPE 1/32 TO 17/64	11/16	-----	3-9/16	P.O.A.	-----
265 COLLET TYPE 1/32 TO 17/64	5/8	-----	3-9/16	P.O.A.	-----
265 BORED TYPE .4375" MAX.	5/8	-----	3-1/8	P.O.A.	-----
375 COLLET TYPE 1/32 TO 3/8	7/8	1-1/4	3-5/8	C74555	C75555
375 BORED TYPE .500" MAX.	7/8	1-1/4	3-5/8	C74557	C75557
#1 MORSE TAPER TYPE	11/16	1-1/4	5	C74598	C75598
375 Q.T. FLOATING TAP SPINDLES	7/8	1-1/4	-----	P.O.A.	P.O.A.
375 Q.C. FLOATING TAP SPINDLES (BILZ)	7/8	1-1/4	-----	P.O.A.	P.O.A.
375 PLAIN FLOATING SPINDLES	7/8	1-1/4	-----	P.O.A.	P.O.A.
BALL BEARING SPINDLE ASSEMBLIES					
375 COLLET TYPE 1/32 TO 3/8	-----	1-1/4	3-3/16	-----	C85346
375 BORED TYPE .500" MAX.	-----	1-1/4	-----	-----	C85471
500 COLLET TYPE 1/32 TO 1/2	-----	1-1/4	3-5/8	-----	C85351
500 BORED TYPE .625" MAX.	-----	1-1/4	-----	-----	C85473
#1 MORSE TAPER TYPE	-----	1-1/4	4-9/16	-----	C85347
#2 MORSE TAPER TYPE	-----	1-1/4	4-15/16	-----	C85348
5/8 ASA SPINDLE	-----	1-1/4	5-5/16	-----	C85349
7/8 ASA SPINDLE	-----	1-1/4	5-15/16	-----	C85350
STUB ASA COLLET TYPE (SPECIFY BORE)	-----	1-1/4	4-5/16	-----	C85406
375 PLAIN FLOATING TAP SPINDLES	-----	1-1/4	-----	-----	C85446
375 Q.T. FLOATING TAP SPINDLES	-----	1-1/4	-----	-----	C85374
375 Q.C. FLOATING TAP SPINDLES (BILZ)	-----	1-1/4	-----	-----	C85377
500 Q.C. FLOATING TAP SPINDLES (BILZ)	-----	1-1/4	-----	-----	C85378
500 Q.T. FLOATING TAP SPINDLES	-----	1-1/4	-----	-----	C85375
ADJUSTABLE DEPTH 375 COLLET TYPE 1/32 TO 3/8	-----	1-1/4	4-3/8	-----	C85418
ADJUSTABLE DEPTH 375 BORED TYPE .500" MAX.	-----	1-1/4	-----	-----	C85491
PITCH COMPENSATING 375 COLLET TYPE 1/32 TO 3/8	-----	1-1/4	4-1/8	-----	C85428
PITCH COMPENSATING 375 BORED TYPE .500" MAX.	-----	1-1/4	-----	-----	C85492
STANDARD ADJUSTABLE DEPTH SPINDLE ASSEMBLIES					
125 COLLET TYPE 1/32 TO 1/8	1/2	-----	3-3/16	C74562	-----
125 BORED TYPE .255" MAX.	1/2	-----	3-3/16	C74590	-----
265 COLLET TYPE 1/32 TO 17/64	11/16	-----	4-3/16	P.O.A.	-----
265 BORED TYPE .4375" MAX.	11/16	-----	4-3/16	P.O.A.	-----
375 COLLET TYPE 1/32 TO 3/8	7/8	1-1/4	4-3/8	C74563	C75563
375 BORED TYPE .500" MAX.	7/8	1-1/4	4-3/8	C74565	C75565
375 Q.T. FLOATING TAP SPINDLES	-----	-----	-----	P.O.A.	P.O.A.
375 Q.C. FLOATING TAP SPINDLES (BILZ)	-----	-----	-----	P.O.A.	P.O.A.
375 PLAIN FLOATING SPINDLES.	-----	-----	-----	P.O.A.	P.O.A.
STANDARD PITCH COMPENSATING SPINDLE ASSEMBLIES					
125 BORED TYPE .255" MAX.	1/2	-----	4-1/8	C74571	-----
265 BORED TYPE .255" MAX.	11/16	-----	4-3/16	P.O.A.	-----
265 COLLET TYPE #0-1/4 TAP	7/8	1-1/4	4-1/8	P.O.A.	P.O.A.
375 COLLET TYPE #0-5/16 TAP	7/8	1-1/4	4-1/8	C74573	C75573
375 BORED TYPE 5/16" TAP MAX.	-----	-----	-----	P.O.A.	P.O.A.
375 Q.T. FLOATING TAP SPINDLES	-----	-----	-----	P.O.A.	P.O.A.
375 Q.C. FLOATING TAP SPINDLES (BILZ)	-----	-----	-----	P.O.A.	P.O.A.
375 PLAIN FLOATING SPINDLES	-----	-----	-----	P.O.A.	P.O.A.

HEAD ACCESSORIES	ITEM #
FIXED POSITION PLATE	C71047
BORED HOLES	C71135
GUIDE RODS AND BUSHED ARMS	C71211/C71212



The maximum angularity of universal joint assemblies should be no more than 22 degrees to obtain best service life.



Fixed Position Plate



Guide Rods & Bushed Arms