

Commander®**MULTIPLE SPINDLE DRILL HEAD****MULTI-DRILL®**

MODEL

200

Adjustable Gear Driven Drill Head

- *Low Cost . . . extremely efficient and versatile drill heads, excellent for short-run multiple hole drilling . . . as well as long runs.*



Normally used for extra light duty applications

The Model 200 Multi-Drill is a versatile and efficient unit designed for close center multiple drilling and tapping operations. Where close centers are not a factor, we recommend a unit in the 400 series. We will adapt the 200 unit to any drill press.

Commander Multi-Drill has on file spindle specifications for most machines. Please furnish us with the make and model number of the machine that our head will be adapted to. (See adaptations page)

In some cases there may be an additional charge for adaptation.

BASIC HEAD 200	ITEM #
Basic Unit without Adaptation 3/8 Minimum Center Distance	C70150
Basic Unit with Adaptation 3/8 Minimum Center Distance	C70151
Basic Unit without Adaptation 1/2 Minimum Center Distance	C70155
Basic Unit with Adaptation 1/2 Minimum Center Distance	C7015

SPECIFICATIONS	
Maximum Number of Spindles	2
Maximum Horsepower Transmitted	1/4
Maximum Torque Transmitted	14 in./lbs.
Maximum Spindle RPM	2000
Maximum Drill Press RPM	900
Minimum Center Distance	3/8
Maximum Drilling Area	1.96"
Ratio (1/2 centers)	1:2
Ratio (3/8 centers)	1:2.2 increase
Approximate Drill Capacity in mild steel	1/8

www.commandermultidrill.com



Proudly made in
Franklin, WI USA

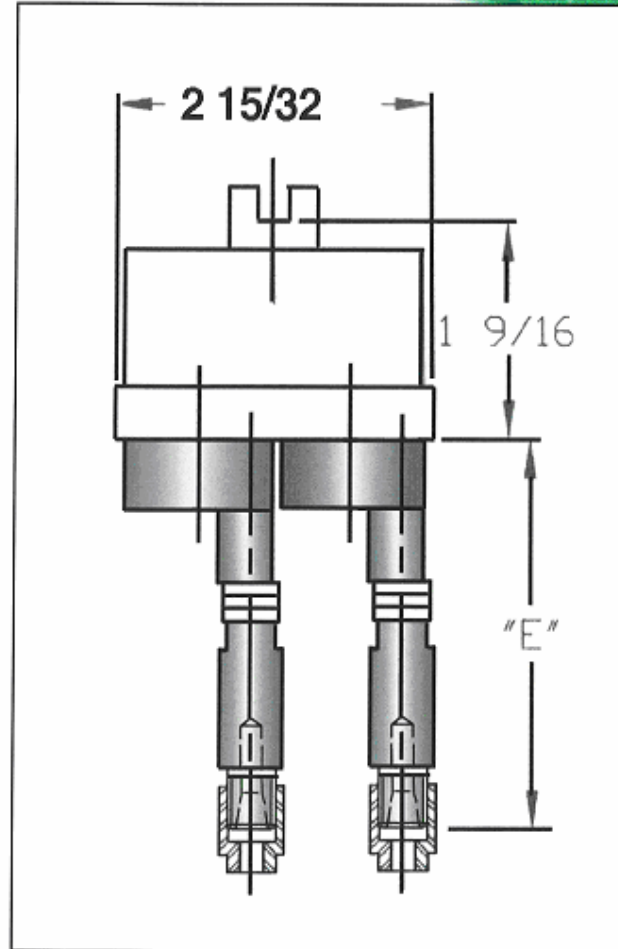
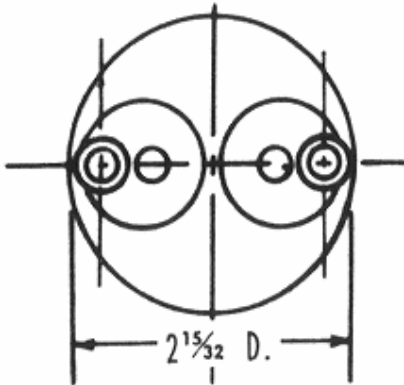

For collet information see
the Commander collets
pages.

COMMANDER 200 SPINDLE HEAD ASSEMBLIES

DESCRIPTION	MIN. CENTERS	LENGTH PART NO.	DIM. "E"
125 COLLET TYPE 1/32 TO 1/8 DIAM.	1/2	C74001	2-7/16
125 BORED TYPE (SPEC. EXACT SIZE MAX. 187)	1/2	C74006	2-9/16
130 COLLET TYPE 1/32 TO 1/8 DIAMETER	3/8	C74020	2-7/16
157 BORED TYPE (SPEC. EXACT SIZE MAX. 157)	3/8	C74007	1-5/8