

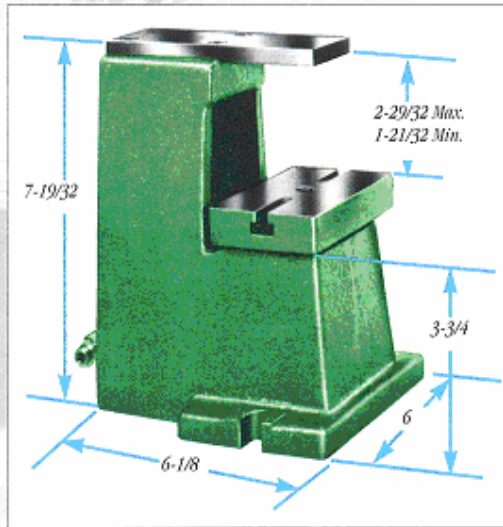

Horizontal Clamping Fixtures



No. X-51A99 Air-Operated Clamping Fixture for holding piece parts where depth of hole or countersink must be maintained from the top of the part.

- Clamping Pressure at 223 Lbs.
- Line Pressure at 100 Lbs.

No. 21HC99 Clamping Fixture for holding piece parts such as stampings and die castings. (Extra Base = 21HCL99)

- Clamping Pressure at 190 Lbs.
- Line Pressure at 100 Lbs.

Dimensions

	<u>Stand. Base</u>	<u>Extra Long base</u>
A	2"	5-7/8"
B	5-5/16"	8-15/16"
C	3-1/2"	4"
D	9-3/4"	11"

Customer must specify height or spindle housing with or without bushing plate slot

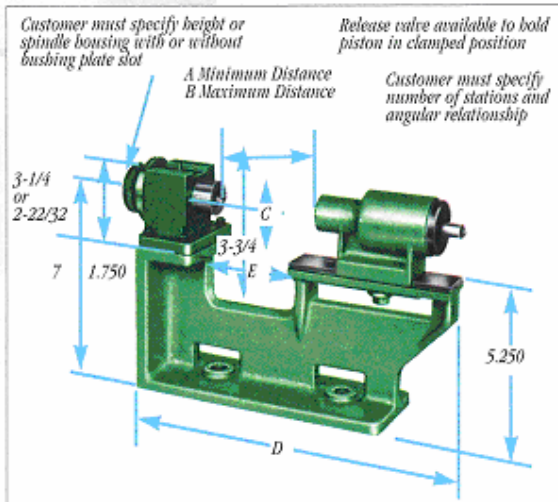
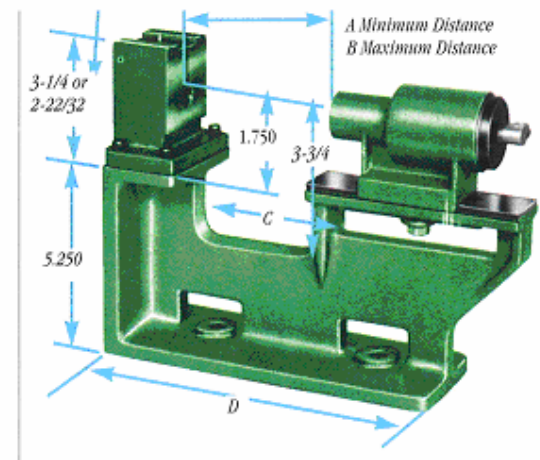

No. 22-X (22HC99) Vertical Hand Index & Horizontal Clamping Fixture for holding piece parts while drilling or tapping a series of holes at angles to each other. Hand Indexing. (22HCL99 - extra long base / 22NX799 - release valve)

- Clamping Pressure at 190 Lbs.
- Line Pressure at 100 Lbs.

Dimensions

	<u>Stand. Base</u>	<u>Extra Long base</u>
A	2	5-7/8
B	5-5/16	8-13/16
C	1.750	1.750
D	9-3/4	11
E	3-1/2	4